

PX-8 (24-VOLT)

PARTS LIST

ALL

Note: Quantity (Qty.) is the number of single parts required in one alternator.



No.	Part #	Description	Qty.	No.	Part #	Description	Qty.
1	PX-8400	Nut, Rotor Shaft (PX-8)	1	43	PX-8813	Washer, Insulator, Output Term. (PX-8)	1
2	PX-8261	Washer, Rotor Shaft Nut (PX-8)	1	44	PX-8205	Washer, Plain, Output Terminal (PX-8)	1
4	PX-8440	Fan, Cooling (PX-8)	1	45	PX-1252-PKG	Washer, 1/2" Split Lock, Grd8 (Pkg 15)	2
5	PX-8058	Fan Shroud (PX-8)	1	46	PX-8967	Nut, 5/16" Thick Jamb, Output Post	1
6	PX-8423	Washer, Lock, Drive End Frame Screw	35	47	PX-8548	Nut, 1/2" Thick, Output Post (PX-8)	1
7	PX-8336	Bolt, Attach, for Shroud/ Cover/ Etc.	35	# 47 is the output cable attaching nut. It is almost twice as tall as the #46 post jamb nut. They do not interchange.			
8	PX-8263-PKG	Screw, Bearing Retainer Plate (Pkg 10)	12	48	PX-8194	Kit, Stator Assembly Plug	1
9	PX-8310	Retainer, Outer Drive End Bearing	1	49	PX-8150	Kit, Cable Support (Positive Cable only)	1
10	PX-8138	Bearing, Outer Drive End (PX-8)	1	50	PX-8968	Kit, Battery Cable Support Kit for the Positive and Negative Cables and both of the Relay & Field Wires.	1
11	PX-8129	Bolt, Frame Attachment (PX-8)	12	51	PX-8999	Bolt, Ground to case (PX-8)	1
12	PX-8307	Housing, Front (PX-8)	1	52	PX-1382-PKG	Washer, Flat, 3/8" ID (Pkg of 15)	1
13	PX-8056	Spacer, Bearing (PX-8)	1	53	PX-8250	Pulley, K10, 4" OD, (PX-8)	1
14	PX-8878	Bearing, Inner Drive End (PX-8)	1	54	PX-8251	Pulley, K8, 3.75" OD, (PX-8)	1
15	PX-8060	Retainer, Inner Drive End Bearing(PX-8)	1	NOTE:PX-833 alternators are normally sold without a pulley. Contact our Sales Department for more information.			
16	PX-8315	Rotor, 24-Volt (PX-8)	1	NOTE: A PX-8 Alternator uses the existing Regulator and Harness. See our information on PX-8 BCK Kits to overhaul 50DN alternators and convert them to Air-Cooled operation. Contact PennTex Certified PX-8 BCK Reman Distributors at www.penntexusa.com			
17	PX-8614	Coil Assembly, Field (PX-8)	1				
18	PX-8249	Bushing, Field Coil Terminal Ins.(PX-8)	3				
19	PX-8568	Stator, 24-Volts, 330-Amps (PX-8)	1				
20	PX-8051	Washer, Insulator, Stator Term. (PX-8)	3				
21	PX-8611	Housing, Rear (PX-8)	1				
22	PX-1115-PKG	Washer, 3/8" Lock (Package of 15)	14				
23	PX-8191	Bolt, Field Coil Attachment (PX-8)	4				
24	PX-8193	Stud, Rectifier Bracket (PX-8)	3				
25	PX-8212	Bushing, Insulator Stator Term. (PX-8)	3				
26	PX-8805	Washer, Plain, Stator Lead (PX-8)	3				
27	PX-8224	Nut, Stator & Diode Lead (PX-8)	9	Toll Free: 877-590-7366 Phone: 817-590-2818 Fax: 817-590-0505 Tech Fax: 817-590-0398 www.penntexusa.com sales@penntexusa.com tech@penntexusa.com			
28	PX-8867	Diode Assembly, Negative or Positive (PX-8)	6				
29A	PX-8036A	Heat Sink, Rectifier, Left (PX-8)	1				
29B	PX-8036B	Heat Sink, Rectifier, Center (PX-8)	1				
29C	PX-8036C	Heat Sink, Rectifier, Right (PX-8)	1				
(Above Heat Sinks are Left, Center, Right from the rear)							
30	PX-8711	Spacer, Rectifier Bracket (PX-8)	3				
31	PX-1098-PKG	Washer, #8 Flat (Package of 25)	3				
32	PX-1113-PKG	Nut, 10-32 Keps (Package of 25)	3				
33	PX-8148	Cover Plate, Rear (PX-8)	1				
34	PX-8039	Insulator, Sleeve Field & Relay Term.	6				
35	PX-8746	Washer, Insulator, Field Term. (PX-8)	3				
36	PX-1103-PKG	Washer, #14 Flat (Package of 10)	9				
37	PX-8326	Nut, Field & Relay Terminal	6				
38	PX-8955	Terminal, Relay (PX-8)	1				
39	PX-8209	Strap, Ground, Field Terminal (PX-8)	1				
40	PX-8055	Terminal, Insulator, Sleeve (PX-8)	2				
41	PX-8246	Bushing, Insulator, Output Term. (PX-8)	1				
42	PX-8038	Stud, Output Terminal (PX-8)	1				

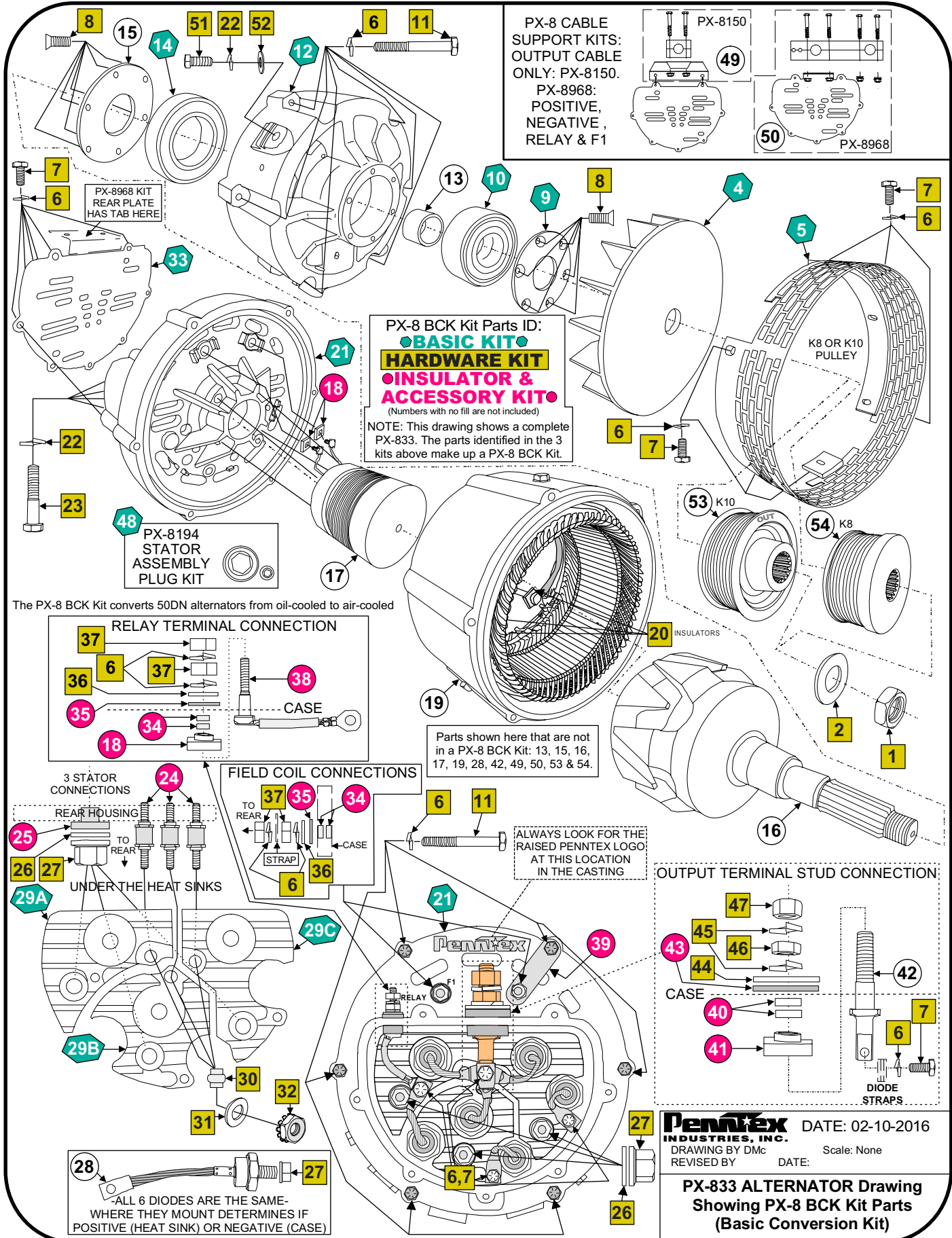

PX-8 CABLE SUPPORT KITS:
OUTPUT CABLE ONLY: PX-8150.
PX-8968:
POSITIVE,
NEGATIVE,
RELAY & F1

PX-8968 KIT REAR PLATE HAS TAB HERE

PX-8 BCK Kit Parts ID:
● **BASIC KIT** ●
● **HARDWARE KIT** ●
● **INSULATOR & ACCESSORY KIT** ●
(Numbers with no fill are not included)
NOTE: This drawing shows a complete PX-833. The parts identified in the 3 kits above make up a PX-8 BCK Kit.

PX-8194 STATOR ASSEMBLY PLUG KIT

The PX-8 BCK Kit converts 50DN alternators from oil-cooled to air-cooled

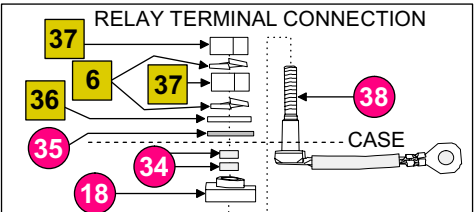

Parts shown here that are not in a PX-8 BCK Kit: 13, 15, 16, 17, 19, 28, 42, 49, 50, 53 & 54.

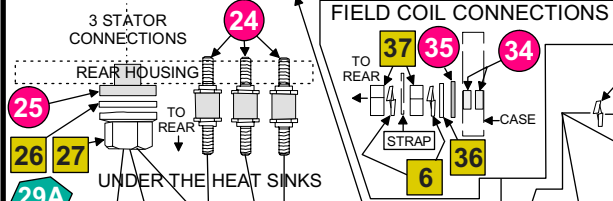

ALWAYS LOOK FOR THE RAISED PENNTEX LOGO AT THIS LOCATION IN THE CASTING

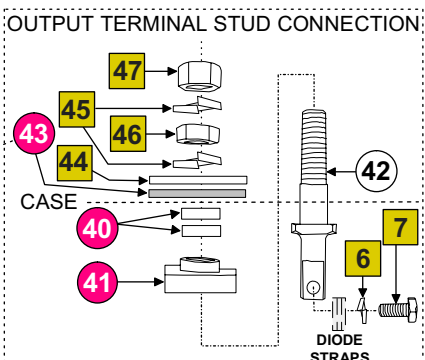

28
ALL 6 DIODES ARE THE SAME - WHERE THEY MOUNT DETERMINES IF POSITIVE (HEAT SINK) OR NEGATIVE (CASE)

Penntex INDUSTRIES, INC. DATE: 02-10-2016
DRAWING BY Dmc Scale: None
REVISED BY DATE:

PX-833 ALTERNATOR Drawing Showing PX-8 BCK Kit Parts (Basic Conversion Kit)

PX-8 BCK (24-VOLT)

PARTS LIST

ALL



See the list of Authorized PennTex PX-8 BCK Dealers at www.penntexusa.com/CRDList

No.	Part #	Description	Qty.
Basic PX-8 BCK (Basic Conversion Kit) Parts:			
4	PX-8440	Fan, Cooling (PX8)	1
5	PX-8058	Fan Shroud (PX8)	1
9	PX-8310	Retainer, Outer Drive End, Bearing	1
10	PX-8138	Bearing, Outer Drive End (PX8)	1
12	PX-8307	Housing, Front (PX8)	1
14	PX-8878	Bearing, Inner Drive End (PX8)	1
21	PX-8611	Housing, Rear (PX8)	1
29A	PX-8036A	Heat Sink, Rectifier, Left (PX8)	1
29B	PX-8036B	Heat Sink, Rectifier, Center (PX8)	1
29C	PX-8036C	Heat Sink, Rectifier Right (PX8)	1
33	PX-8148	Cover Plate, Rear (PX8)	1
48	PX-8194	Kit, Stator Assembly Plug	1
PX-8995: PX-8 BCK Hardware Kit Parts:			
1	PX-8400	Nut, Rotor Shaft (PX8)	1
2	PX-8261	Washer, Rotor Shaft Nut (PX8)	1
6	PX-8423	Washer, Drive End Frame Screw, Lock	35
7	PX-8336	Bolt, Attaching, for Shroud/ Cover/ Etc.	35
8	PX-8263-PKG	Screw, Bearing Retainer Plate *	12
11	PX-8129	Bolt, Frame Attachment	12
22	PX-1115-PKG	Washer, 3/8" Lock *	14
23	PX-8191	Bolt, Field Coil Attachment	4
26	PX-8805	Washer, Plain, Stator Lead (PX8)	3
27	PX-8224	Nut, Stator & Diode Lead (PX8)	9
31	PX-1098-PKG	Washer, # 8 Flat *	3
32	PX-1113-PKG	Nut, 10-32 Keps *	3
36	PX-8125	Washer, Field Terminal (PX8)	9
37	PX-8326	Nut, Field Terminal	6
44	PX-8205	Washer, Plain, Output (PX8)	1
45	PX-1252	Washer, 1/2" Split Lock, Grade 8	2
46	PX-8967	Nut, 5/16" Thick, Jamb, Output Post	1
47	PX-8548	Nut, 1/2" Thick, Output Post, Cable Attaching	1
51	PX-8999	Bolt, Ground (PX8)	1
52	PX-1382-PKG	Washer, Flat, 3/8" *	1
***	PX-8645	Kit, Oil Line Cap (PX8) (***)not shown	1
PX-8647: PX-8 BCK Insulator & Accessory Kit			
18	PX-8249	Bushing, Field Terminal Insulator	3
20	PX-8051	Washer, Insulator, Stator Terminal	3
24	PX-8193	Stud, Rectifier Bracket (PX8)	3
25	PX-8212	Bushing, Ins. Stator Term. (PX8)	3
30	PX-8711	Spacer, Rectifier Bracket (PX8)	3
34	PX-8039	Insulator, Sleeve, Field&Relay Terminal	6
35	PX-8746	Washer, Insulator, Field Terminal (PX8)	3
38	PX-8955	Terminal, Relay (PX8)	1

No.	Part #	Description	Qty.
39	PX-8209	Strap, Ground, Field Terminal (PX8)	1
40	PX-8055	Terminal, Insulator Sleeve (PX8)	2
41	PX-8246	Bushing, Insulator, Output Terminal (PX8)	1
43	PX-8813	Washer, Insulator, Output Terminal (PX8)	1
All parts in the 3 lists above are included in a PX-8 BCK Kit			
Parts in a PX-833 Air-Cooled Alternator Not Included in a PX-8 BCK Kit:			
13	PX-8056	Spacer, Bearing (PX8)	1
15	PX-8060	Retainer, Inner Drive End, Bearing	1
16	PX-8315	Rotor, 24-Volt (PX8)	1
17	PX-8614	Coil Assembly, Field (PX8)	1
19	PX-8568	Stator, 24-Volt, 330-Amp (PX8)	1
28	PX-8867	Diode Assembly (PX8)	6
42	PX-8038	Stud, Output Terminal (PX8)	1
Other Parts For a PX-833 or PX-8 BCK Kit:			
49	PX-8150	Kit, Cable Support (Positive cable only)	1
50	PX-8968	Kit, Positive & Negative Cable Support	1
(# 49 uses the PX-8148 Rear Cover)			
Parts Not Included in a Standard Kit or a BCK Kit:			
53	PX-8250	Pulley, K10, 4" O.D. (PX8)	1
54	PX-8251	Pulley, K8, 3.75" O.D. (PX8)	1
A 24-Volt PX-833 Alternator or PX-8 BCK Kit uses the existing Voltage Regulator and Harness on the vehicle.			
PX-8 Series Part Numbers:			
	PX-833	Complete 24-Volt Air-Cooled 50DN Upgrade	
	PX-8 BCK	Complete parts kit to convert an oil-cooled 50DN to a 24-Volt Air-Cooled alternator	
* NOTE: All part numbers ending with "PKG" are available only in packages or multiples. See list on Page 80 for more information. All "Quantities" on this page are a number of individual parts.			
For PX-8 BCK Kits contact a PennTex Certified Reman Distributor (CRD) at www.penntexusa.com			
Contact PennTex: Phone: 877-590-7366, 817-590-2818 Sales Fax: 817-590-0505 Tech Fax: 817-590-0398 sales@penntexusa.com tech@penntexusa.com			
PennTex 02-11-2016			

Cable Support Clamp Kits for

PX-833 Alternator or 50DN
 rebuilt with PennTex PX-8 BCK
 oil-to-air conversion kit.
 Contact PennTex PX-8
 Certified Reman Distributors
 & Warehouse Distributors
 at www.penntexusa.com
 PennTex: 877-590-7366
sales@penntexusa.com
tech@penntexusa.com

PX-8150

Attaches to original
 cover plate

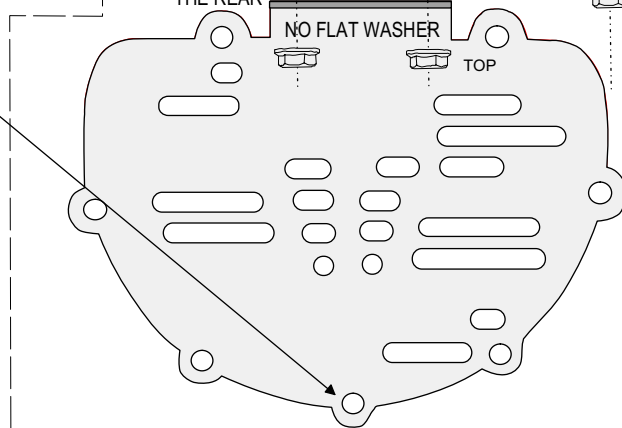
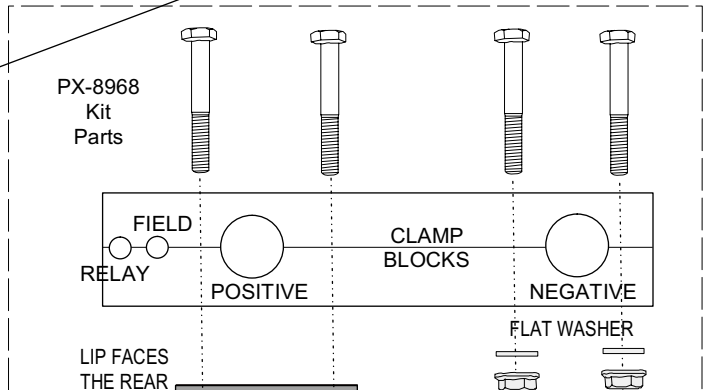
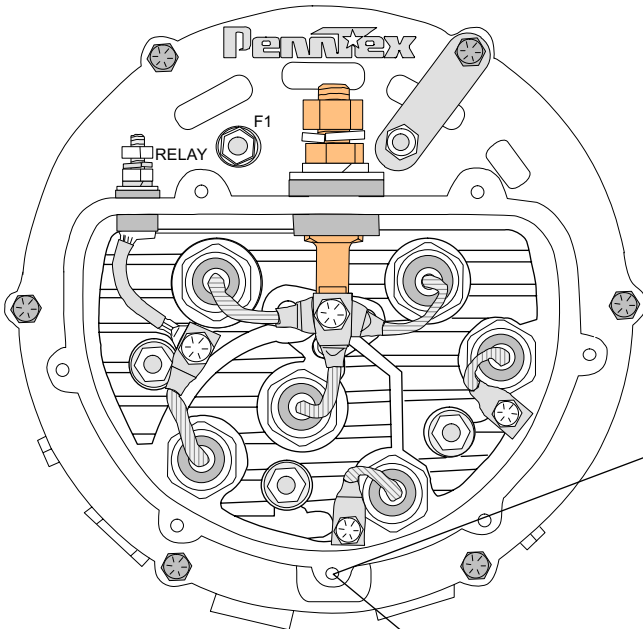
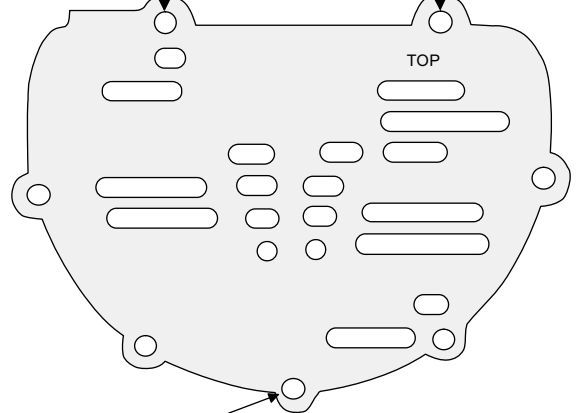
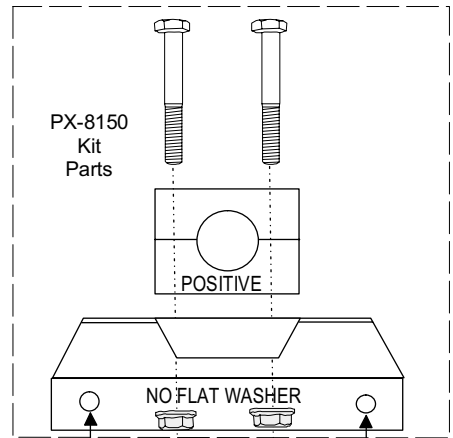

PX-8968

Cover plate with
 mounting flange
 for clamp block
 is included.