

PX-220R-5T

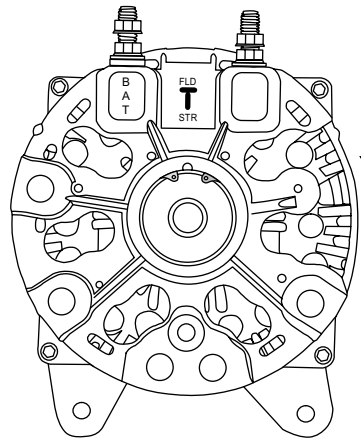
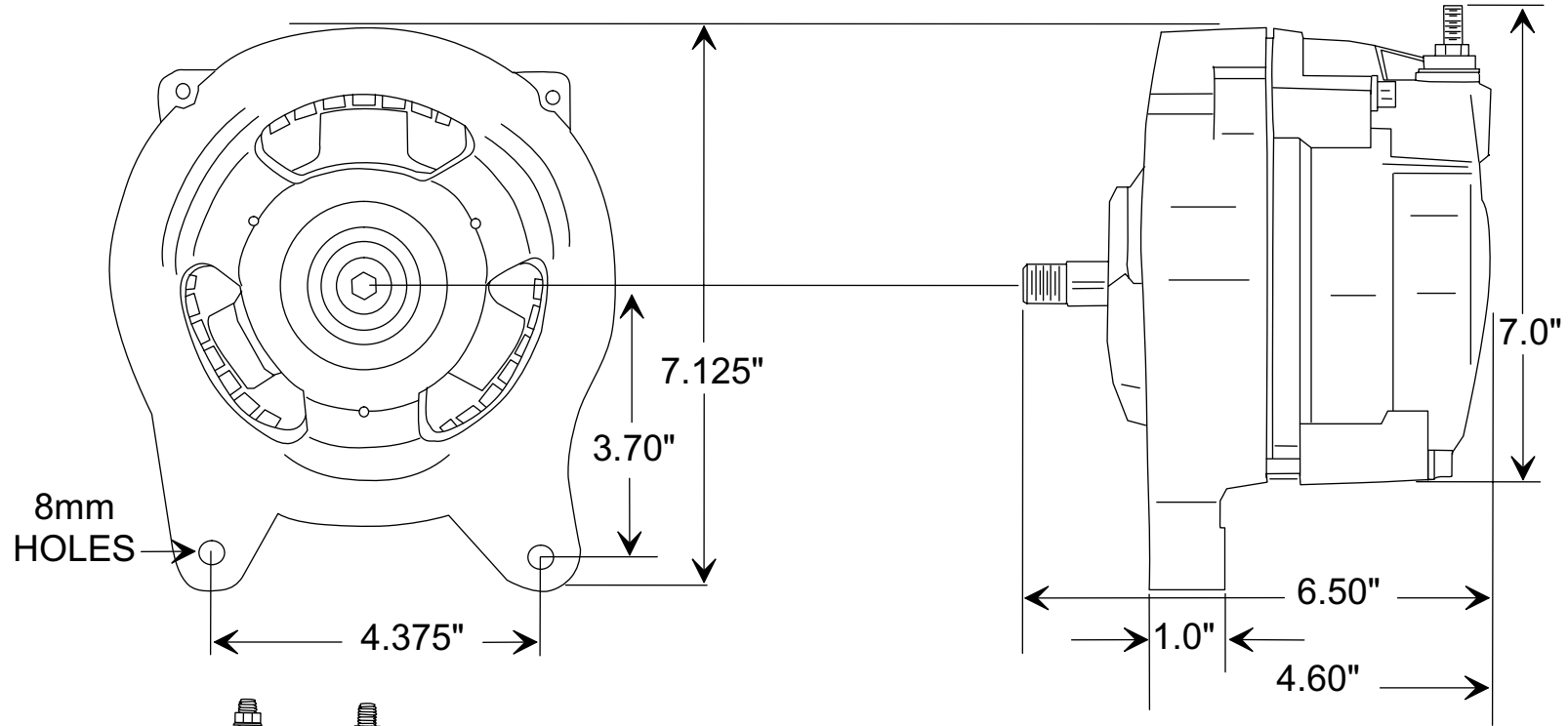

THE PX-2R-5T HAS THIS CUTOUT IN THE REAR HOUSING.

NOTE:

ALL DIMENSIONS ARE LISTED FOR QUICK REFERENCE. CONTACT PENNTEX FOR PRECISE MEASUREMENTS IF REQUIRED FOR BRACKETS OR SPECIAL APPLICATIONS.

PennTex INDUSTRIES, INC. DATE: 01-07-2008
DRAWING BY DMc. Scale: None

**PX-2R-5T ALTERNATOR
FROM PX-220R-5T KIT
14 VOLT, 200 AMP,
MODULAR MOUNT**