

# PX-220T-5

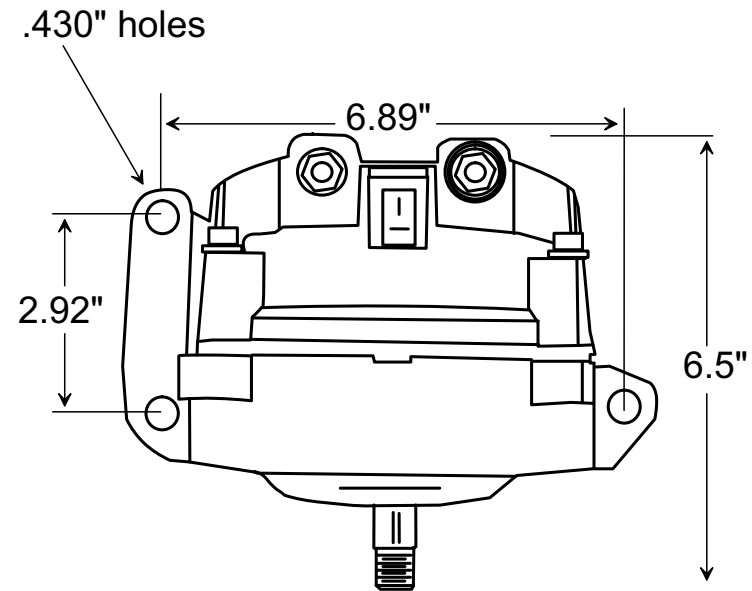
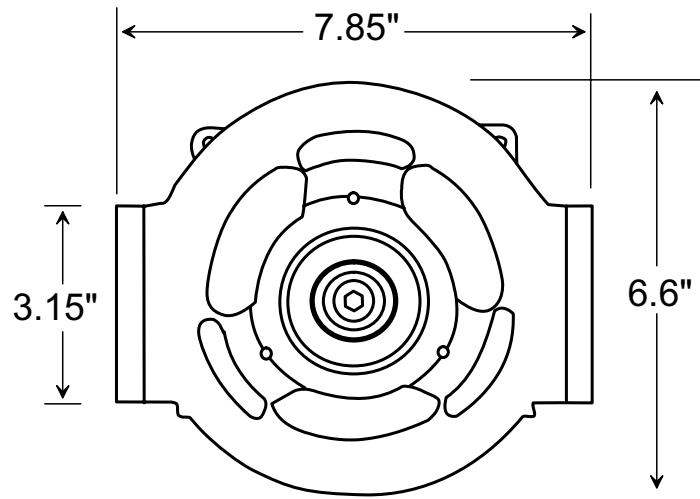

**NOTE:**

ALL DIMENSIONS ARE LISTED FOR QUICK REFERENCE. CONTACT PENNTEX FOR PRECISE MEASUREMENTS IF REQUIRED FOR BRACKETS OR SPECIAL APPLICATIONS.

**PennTex**  
INDUSTRIES, INC.  
DRAWING BY DMc.

DATE: 01-07-2008

Scale: None

**PX-2T-5 ALTERNATOR  
FROM PX-220T-5 KIT,  
14 VOLT, 200 AMP,  
TANGENT MOUNT**