



Get The PennTex Advantage!
PERFORMANCE, ENDURANCE AND SATISFACTION

ASSEMBLE A PX-2, PX-4G-5, PX-5 OR PX-7 ALTERNATOR

Short Generic Version (PX-5RD-230 shown here - other models are similar)

- 1) Press the front bearing into the front housing. Install the three retainer clips.
- 2) Press the rotor into the front bearing. Install the fan spacer, fan and pulley. Install the proper washers and pulley nut. Tighten the pulley retaining nut with a 1/2" impact.
- 3) Assemble the brush holder with a brush locating pin for installation in the rear housing.
- 4) Install brush holder, capacitor, heat sinks and straps in the rear housing.
- 5) Install the stator in the rear housing. Torque the attaching nuts to 50 inch pounds. Apply industrial grade silicone on the nuts and other screws as a retainer.
- 6) Install the rear housing on the rotor/ front assembly. Insert the case attaching bolts and start them in the threads of the front housing. Note the position of the brush retainer pin (inset).
- 7) Slowly remove the brush retaining pin. There should be two distinct "pops" when each brush comes loose from the pin and contacts the rotor slip rings.
- 8) Install the rear bearing wave washer in the rear bearing cavity.
- 9) Set the rear bearing on the rear housing. Use the PX-2534 Rear Bearing Installation Tool to complete the proper installation of the rear bearing. The PX-2534 Kit includes tools to install PX-2, PX-4G-5, PX-5, and PX-7 rear bearings. See attached instructions for detail.
- 10) Using a hand-operated press, push the rear bearing into the housing and on to the rotor.
- 11) Tighten the 4 case bolts equally in a cross pattern. Install the rear bearing snap ring.
- 12) Spin the alternator by hand to check for any binding or noise. These alternators have very close tolerances between the rotor and stator. If needed, the four case bolts can be loosened and the stator can be aligned for a better fit. Retighten the 4 case bolts as required. Re-spin the alternator by hand to check it. Machine test for proper output.

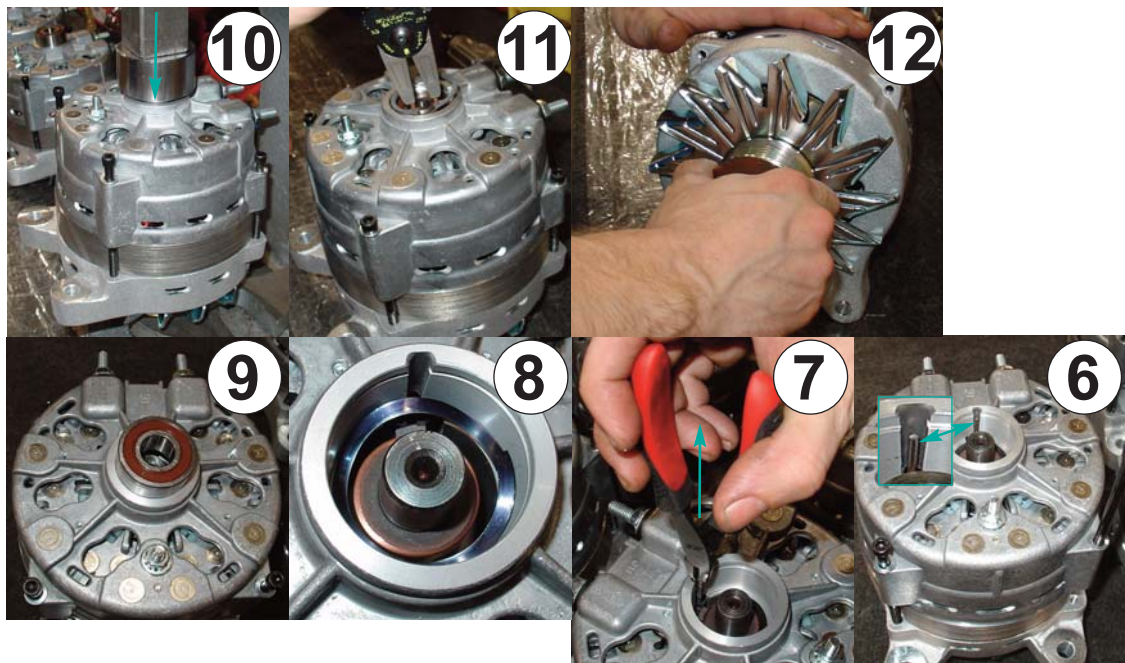
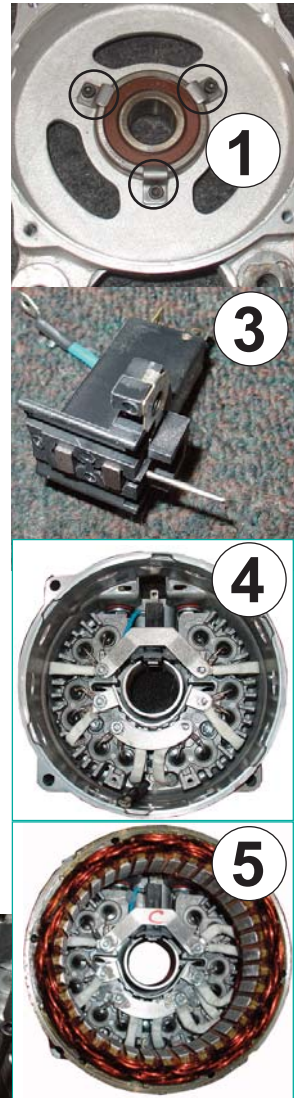

Links to:
PX-2 Parts
PX-4G-5 Parts
PX-5 Parts
PX-7 Parts

PERFORMANCE, ENDURANCE AND SATISFACTION

PennTex
INDUSTRIES, INC.

Manufacturers of

High Efficiency Alternators and
Mobile Electronic Devices.

Corporate:
202 Plaza Drive
Manchester, PA 17345
Ph: 717-266-8762
Fax: 717-266-7803

Manufacturing/ Sales/ Tech/ Warranty:
7620 Flagstone Drive
Fort Worth, TX 76118
Ph: 817-590-2818, Toll Free: 877-590-7366
Fax: 817-590-0505, Tech Fax: 817-590-0398

www.penntexusa.com
email: sales@penntexusa.com
tech@penntexusa.com

PX-2, PX-4G-5, PX-5, and PX-7 Rear Bearing Installation Instructions Using a PX-2534 Assembly Tool

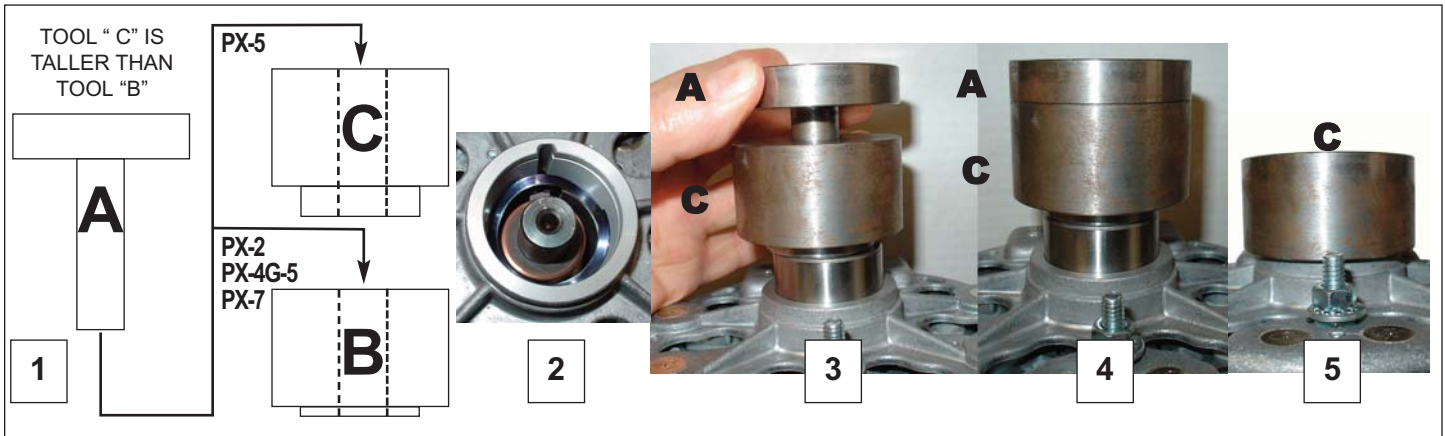

NOTE: the procedures below are used with PX-2, PX-4G-5, PX-5, and PX-7 Series alternators that use a snap ring rear bearing retainer. This tool isn't used on 1999 and older PennTex models that use a 3-screw rear bearing retainer plate.

The rear bearing is the second-to-last part installed during assembly of the alternator. The rear bearing is installed from the rear, pressing into the rear housing and on to the rotor shaft. If an attempt is made to install the rotor with the rear bearing installed on the rotor, or with the rear bearing already installed in the rear housing, severe damage will be done.

Each rear bearing installation kit will contain three pieces:

A: Rear Bearing Alignment Tool (*this tool can also be used to press the rotor out*)

B: PX-2, PX-4G-5, and PX-7 Rear Bearing Press Tool

C: PX-5 Rear Bearing Press Tool

PX-2, PX-4G-5
 & PX-7
 Rear Bearing
 PX-5
 Rear
 Bearing



INSTALLATION PROCEDURES- NUMBERS REFER TO ABOVE ILLUSTRATIONS:

1: This tool properly positions the rear bearing in the case. It is pressed in from the rear of the almost completely assembled alternator. Note: the four housing thru-bolts that hold the front and rear housings together should be installed but loose enough to allow for the housings to shift around. Use tools **A** and **B** when assembling a PX-2, PX-4G-5, or PX-7 alternator. Use tools **A** and **C** when assembling a PX-5. Tools **B** and **C** are a specific height and are used in specific alternator series to position the rear bearing properly in the rear housing. The bearing all have the same OD. The PX-5 bearing
 NOTE: If the bearing is not pressed down properly, the bearing, case, and rotor can be damaged. Place the alternator on an arbor press with the pulley facing down.

2: Install the PX-1249 wave washer in the rear bearing cavity. The same wave washer is used in these four alternator series.

3: Set the rear bearing loosely on the rear bearing cavity. Depending on the alternator Series, place tool **B** or **C** on the bearing. PX-5 Series use **C**, and PX-2, PX-4G-5, & PX-7 use **B**. Place tool **A** on top of **B** or **C**, and move the tools around until tool **A** centers itself inside the inner diameter of the rear bearing.

4: Press the tools and the bearing into the cavity until tool **A** bottoms out on the rotor shaft.

5: Remove tool **A** from tool **B** or **C** and continue to press the bearing down until **B** or **C** bottoms out on the rear housing.

The rear bearing is now in the proper location and the PX-1366 snap ring retainer (same in all four Series) can be installed.

Finish tightening the four case thru-bolts. Spin the alternator and check for binding or interference. Adjust the bolts as required.

Check the assembly on an alternator tester. Check for output, noises, and proper alignment of all exterior alternator parts.