



PennTex INDUSTRIES, INC.

MODEL

PX-3 Series 12-volt
200 to 305 amps

HIGH AMPERAGE / HEAVY DUTY ALTERNATORS/CHARGING SYSTEMS

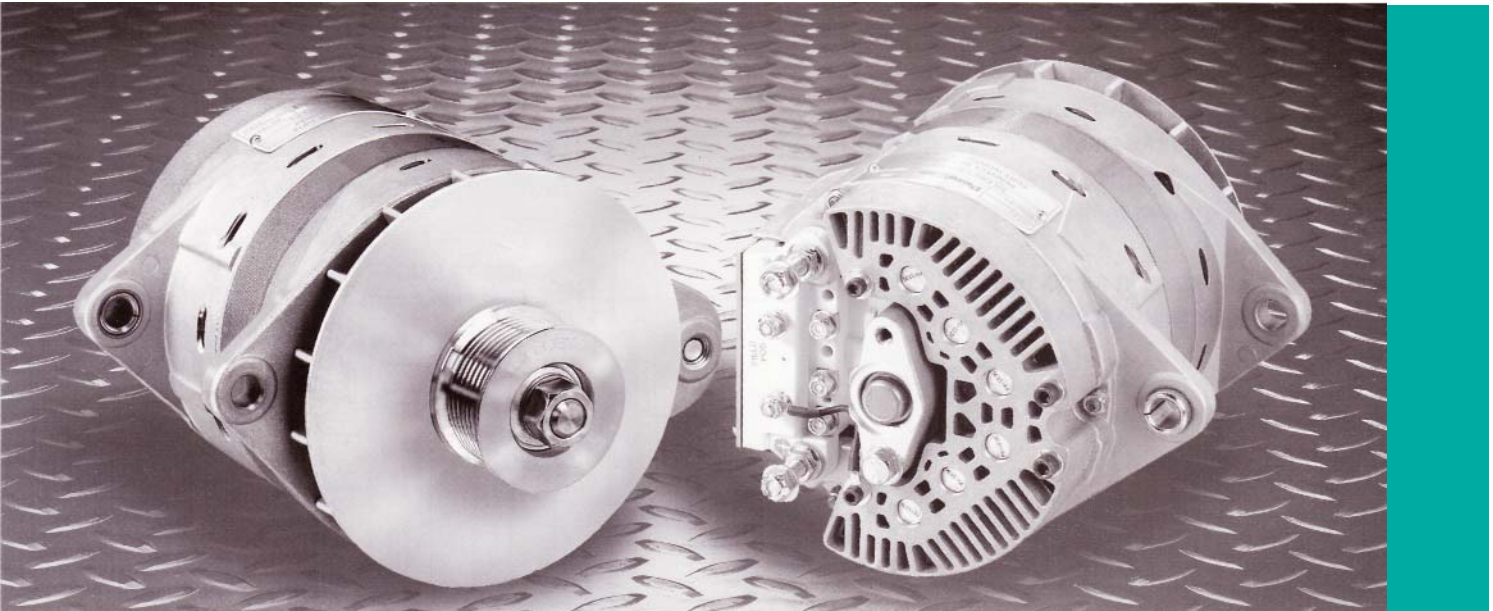

200/180 AMPS

MODEL PX-320S TESTED & PROVEN		
ROTOR RPM	AMPS @ 13.5 VOLTS	
	COLD (SAE)	HOT (200°F)
1800	95	80
2000	135	115
2250	150	125
2500	170	140
2750	180	150
3000	190	160
3500	200	165
4000	210	175
4500	215	180
5000	220	185

250/210 AMPS

MODEL PX-325S TESTED & PROVEN		
ROTOR RPM	AMPS @ 13.5 VOLTS	
	COLD (SAE)	HOT (200°F)
1800	85	70
2000	130	110
2250	145	120
2500	180	150
2750	190	160
3000	210	175
3500	225	185
4000	240	200
4500	245	205
5000	255	210

305/250 AMPS

MODEL PX-330S TESTED & PROVEN		
ROTOR RPM	AMPS @ 13.5 VOLTS	
	COLD (SAE)	HOT (200°F)
1800	50	40
2000	95	80
2250	130	110
2500	170	140
2750	200	165
3000	225	185
3500	255	210
4000	275	225
4500	285	235
5000	305	250

APPLICATIONS

- Buses and all other vehicles that require high amperage output.
- See application guide or contact PennTex for availability of specific application.

OPTIONS

- Contact PennTex with specific requirements.



PX-4000
VOLTAGE
REGULATOR



Special Features

- 1) 3/8" battery post.
- 2) Heavy duty hand wound high output stator.
- 3) Heavy duty long life brushes.
- 4) Heavy duty dual plane balanced rotor.
- 5) Heavy duty bearings with high temperature seals and grease.
- 6) Eighteen (18) press fit heavy duty diodes.
- 7) Specially designed heavy duty regulator which produces higher output ratings; runs cooler than current industry standards.
- 8) Regulator has ground fault and high voltage protection.
- 9) GXL wire is standard in all harnesses.
- 10) Standard OEM belt can be used in most applications.
- 11) Standard OEM mounting - no brackets needed in most applications.
- 12) Weight: approximately 25 pounds.

PennTex Industries recommends using a minimum of 2 gauge battery and ground cable. For maximum performance, route 2 gauge battery cable, or larger, from the alternator battery post directly to the battery positive stud. The ground wire from the alternator should be a minimum of 2 gauge cable and be bolted directly to a chassis ground or to the negative side of the battery.

WARRANTY

PENNTEx INDUSTRIES, INC., STANDARD WARRANTY IS EIGHTEEN (18) MONTHS OR 75,000 MILES -- WHICHEVER OCCURS FIRST, WHEN INSTALLED ON A NEW OEM VEHICLE. AFTERMARKET INSTALLATIONS HAVE A WARRANTY OF TWELVE (12) MONTHS/UNLIMITED MILES.

Dimensions

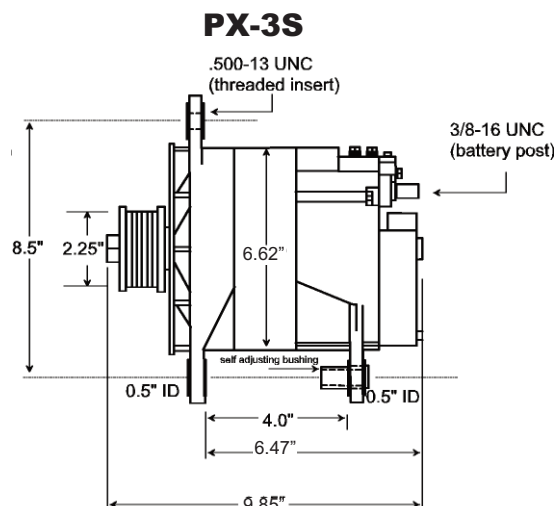

Scale: None

PERFORMANCE ENDURANCE AND SATISFACTION

PennTex
INDUSTRIES, INC.

Manufacturers of
High Efficiency Alternators and
Mobile Electronic Devices.

Corporate:
202 Plaza Drive
Manchester, PA 17345
Ph: 717-266-8762
Fax: 717-266-7803

Manufacturing/ Sales/ Tech/ Warranty:
7620 Flagstone Drive
Fort Worth, TX 76118
Ph: 817-590-2818
Toll Free: 877-590-7366
Fax: 817-590-0505, Tech Fax: 817-590-0398

www.penntexusa.com
Email: sales@penntexusa.com
tech@penntexusa.com