

PX-420G-5

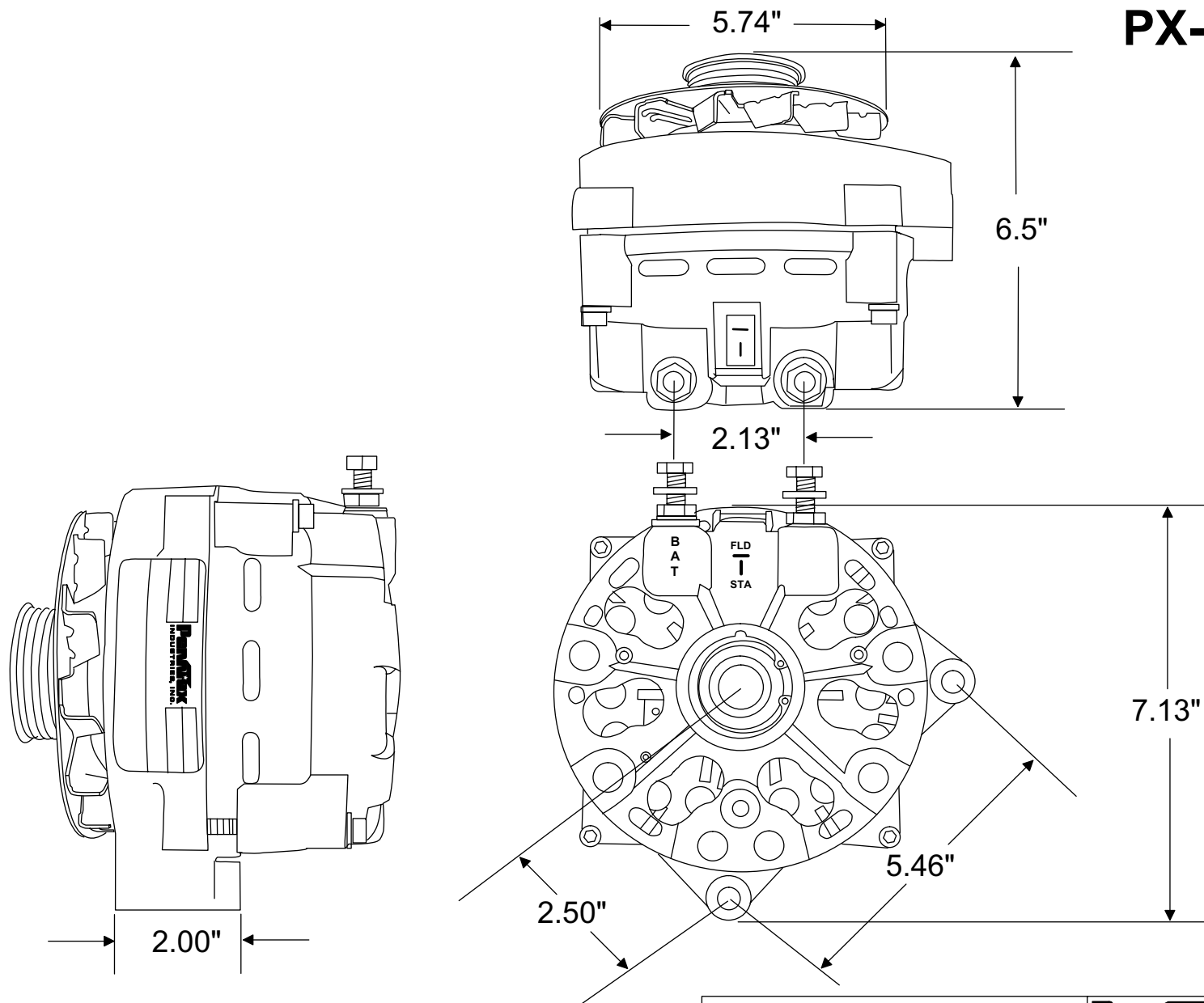

NOTE:

ALL DIMENSIONS ARE LISTED FOR QUICK REFERENCE. CONTACT PENNTEX FOR PRECISE MEASUREMENTS IF REQUIRED FOR BRACKETS OR SPECIAL APPLICATIONS.

PennTex
INDUSTRIES, INC.
DRAWING BY DMc

DATE: 08-03-2008

Scale: None

PX-420G-5
ALTERNATOR, 200 AMP,
14 VOLT, 2" SPOOL MOUNT