

PX-422V

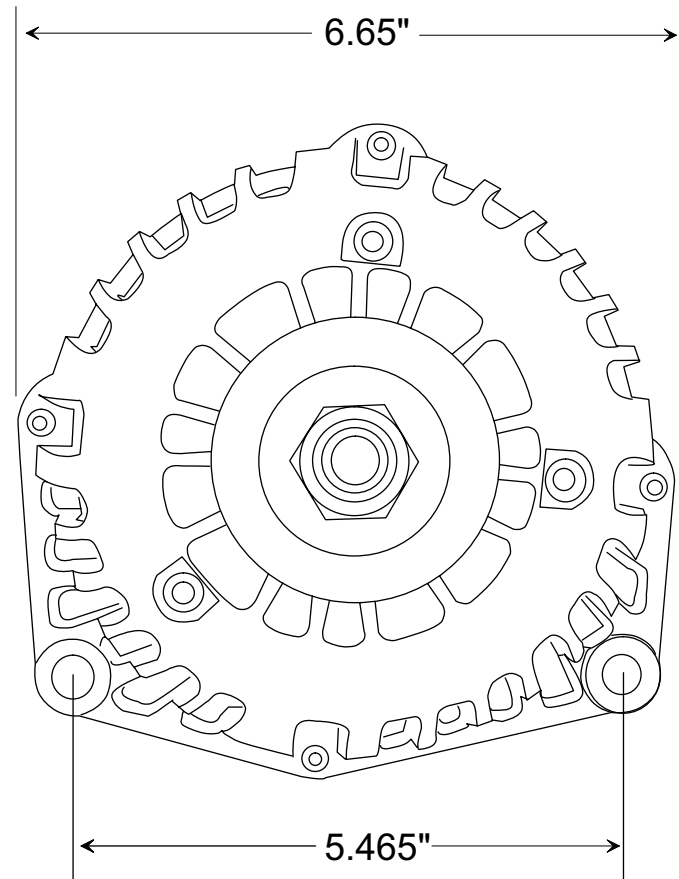
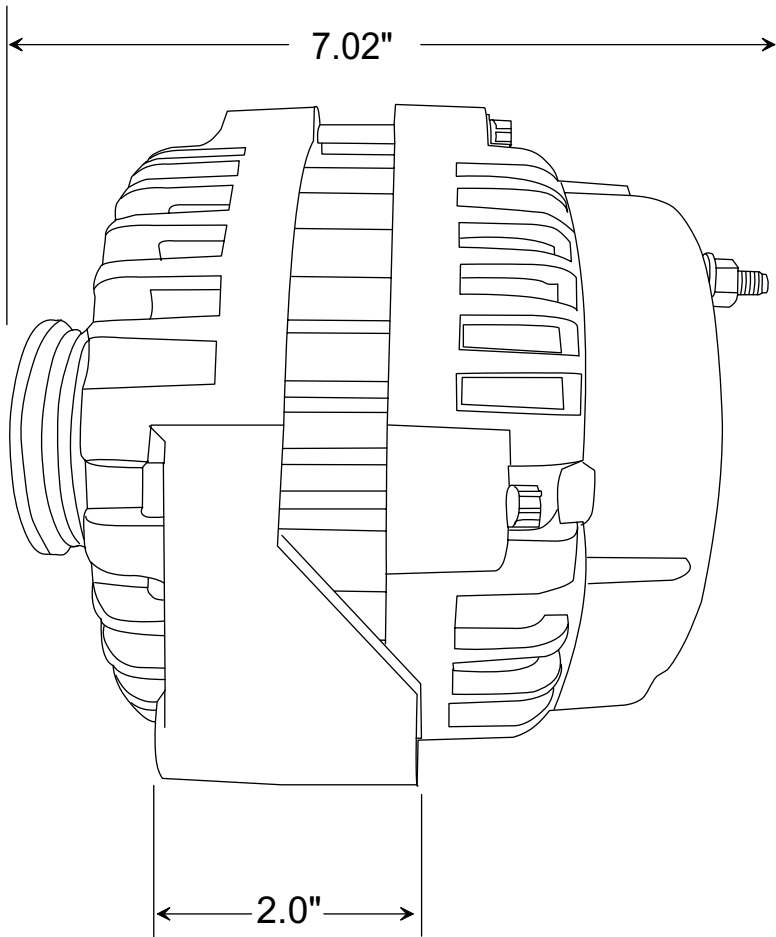

NOTE:

ALL DIMENSIONS ARE LISTED FOR QUICK REFERENCE. CONTACT PENNTEX FOR PRECISE MEASUREMENTS IF REQUIRED FOR BRACKETS OR SPECIAL APPLICATIONS.

PennTex
INDUSTRIES, INC.
DRAWING BY DMC

DATE: 01-14-2008

Scale: None

**PX-4V-220 ALTERNATOR
FROM PX-422V KIT,
12 VOLT, 220 AMP**