

PX-616S

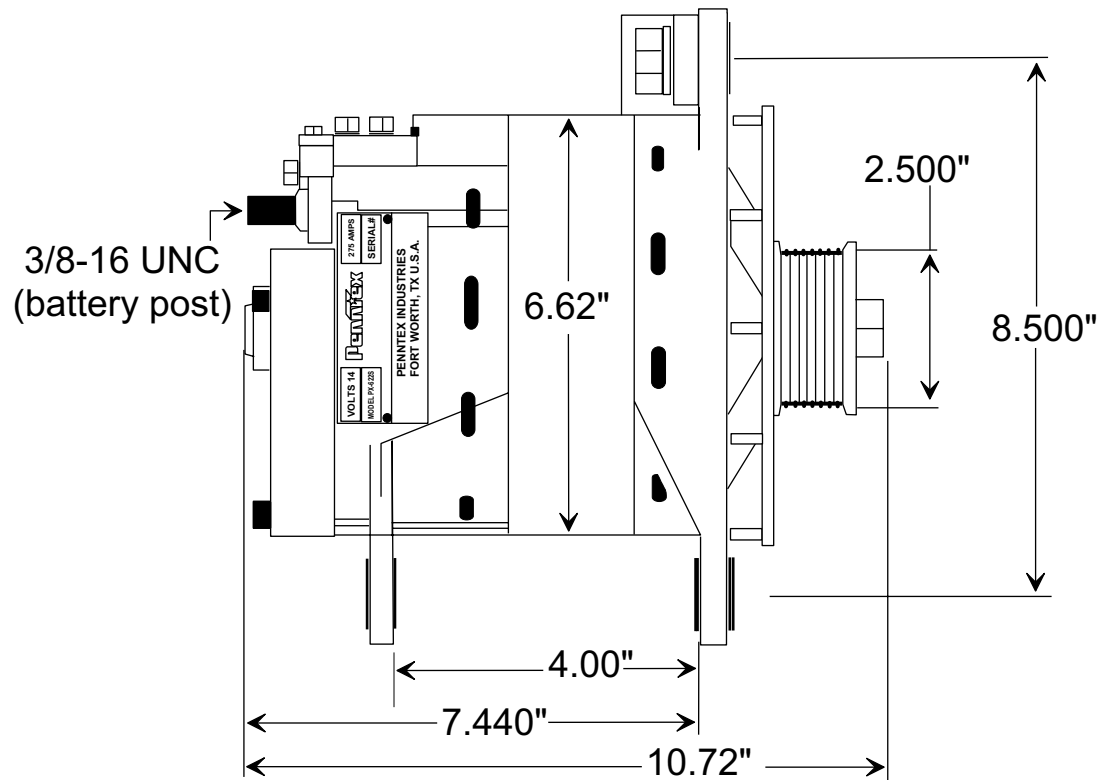

NOTE:

ALL DIMENSIONS ARE LISTED FOR QUICK REFERENCE. CONTACT PENNTEX FOR PRECISE MEASUREMENTS IF REQUIRED FOR BRACKETS OR SPECIAL APPLICATIONS.

PennTex
INDUSTRIES, INC.
DRAWING BY DMc

DATE: 01-14-2008

Scale: None

**PX-6S-160 ALTERNATOR
FROM PX-616S KIT,
28 VOLT, 160 AMP,
J-180 MOUNT**