

PX-627Q

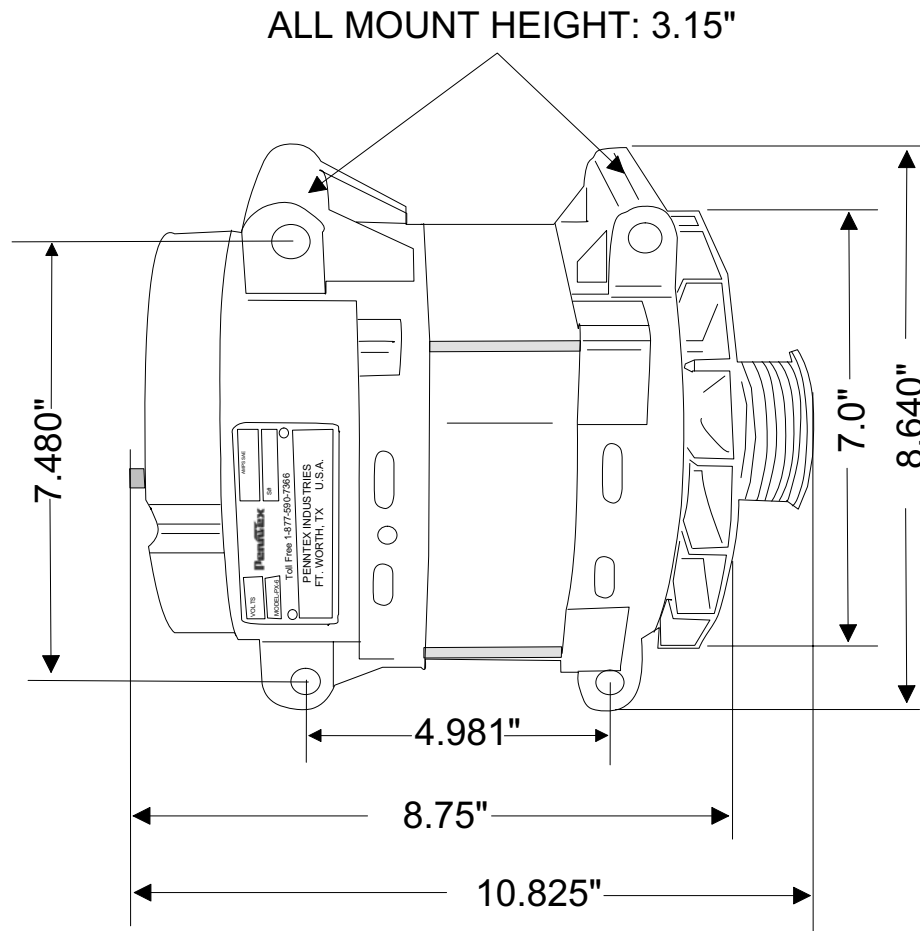

NOTE:

ALL DIMENSIONS ARE LISTED FOR QUICK REFERENCE. CONTACT PENNTEX FOR PRECISE MEASUREMENTS IF REQUIRED FOR BRACKETS OR SPECIAL APPLICATIONS.

Penntex
INDUSTRIES, INC.
DRAWING BY DMc

DATE: 01-23-2008

Scale: None

**PX-6Q-275 ALTERNATOR
FROM PX-627Q KIT, 12 VOLT,
275 AMPS, QUAD MOUNT**