



**PennTex** INDUSTRIES, INC.

MODEL **PX-7** Series **DUAL OUTPUT POST**  
**12-volt 230/250 amps**

**HIGH AMPERAGE / HEAVY DUTY  
 ALTERNATORS / CHARGING SYSTEMS**



**PX-7TD**



**PX-7RD**



**PX-4000  
 VOLTAGE  
 REGULATOR**



**PX-7000  
 VOLTAGE  
 REGULATOR**

**230/190 AMPS**

MODEL PX-723 TESTED AND PROVEN		
ROTOR RPM	AMPS @ 13.5 VOLTS	
	COLD (SAE)	HOT (200°F)
1800	110	90
2000	130	110
2250	155	130
2500	170	140
2750	185	155
3000	195	160
3500	210	175
4000	215	180
4500	225	185
5000	230	190

**250/210 AMPS**

MODEL PX-725 TESTED AND PROVEN		
ROTOR RPM	AMPS @ 13.5 VOLTS	
	COLD (SAE)	HOT (200°F)
1800	95	80
2000	125	105
2250	145	120
2500	175	145
2750	190	160
3000	205	170
3500	225	185
4000	235	195
4500	240	200
5000	250	210

The same output as a PennTex PX-5 Series and approximately 1/4" shorter in overall length.

**WARRANTY**

PENNTEx INDUSTRIES, INC. STANDARD WARRANTY IS EIGHTEEN (18) MONTHS OR 75,000 MILES – WHICHEVER OCCURS FIRST, WHEN INSTALLED ON A NEW OEM VEHICLE. AFTERMARKET INSTALLATIONS HAVE A WARRANTY OF TWELVE (12) MONTHS/UNLIMITED MILES.

**APPLICATIONS**

- Specifically designed to perform in the Ford E-Series 6.0L & 6.8L high heat environment.
- Buses and all other vehicles that require high amperage output.
- See application guide or contact PennTex for availability of specific application.

**OPTIONS**

- PX-7TD-230/250 with 6 or 12 O'clock posts available.
- PX-7000 Regulators are used in some 2009 & up Ford applications. See application guide for info.



## Special Features

- 1) Dual 5/16" positive output posts.
- 2) Heavy duty hand wound high output stator.
- 3) Heavy duty dual plane balanced rotor.
- 4) Heavy duty long life brushes.
- 5) Heat sinks designed for efficient cooling.
- 6) Heavy Duty bearings with high temperature seals and grease.
- 7) Eighteen (18) press fit 60 amp diodes.
- 8) Specially designed heavy duty regulator that produces higher output ratings; runs cooler than current industry standards.
- 9) Regulator has ground fault and high voltage protection.
- 10) GXL wire is standard in all harnesses.
- 11) Weight: Approximately 25 pounds.

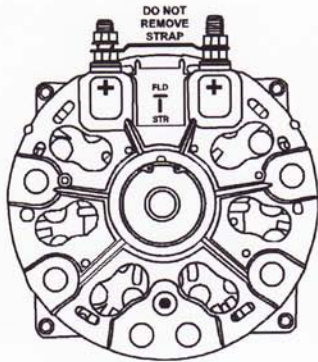

**PennTex Industries** recommends using a minimum of 2 gauge battery and ground cable. For maximum performance route 2 gauge battery cable or larger from the alternator battery post directly to the battery positive stud. The ground cable from the alternator should also be a minimum of 2 gauge cable and should be bolted directly to a chassis ground or the negative side of the battery.

## Dimensions

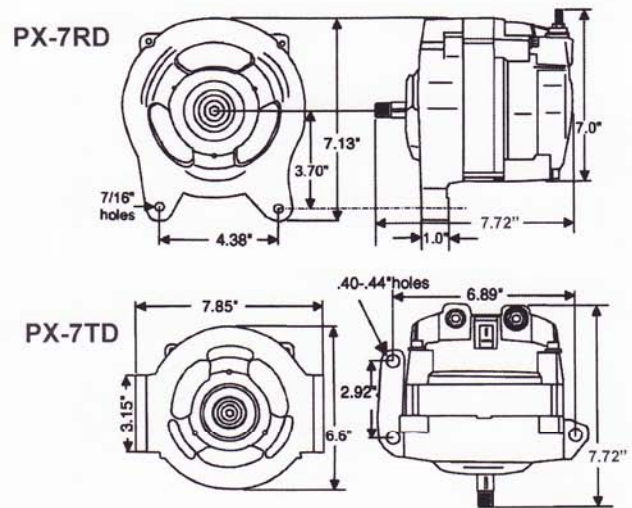

All dimensions are listed for quick reference. Contact PennTex for precise measurements if required for brackets or special applications.



PX-7010 TPS Shield (Ford TPS and RTV not included). The PX-7010 TPS Shield Kit is designed for Ford 6.8 L V-10 applications where the PennTex alternator is in close proximity to the Throttle Position Sensor.

## PERFORMANCE ENDURANCE AND SATISFACTION

**PennTex**  
INDUSTRIES, INC.

Manufacturers of  
High Efficiency Alternators and  
Mobile Electronic Devices.

**Corporate:**  
202 Plaza Drive  
Manchester, PA 17345  
Ph: 717-266-8762  
Fax: 717-266-7803

**Manufacturing/ Sales/ Tech/ Warranty:**  
7620 Flagstone Drive  
Fort Worth, TX 76118  
Ph: 817-590-2818, Toll Free: 877-590-7366  
Fax: 817-590-0505, Tech Fax: 817-590-0398

[www.penntexusa.com](http://www.penntexusa.com)  
email: [sales@penntexusa.com](mailto:sales@penntexusa.com)  
[tech@penntexusa.com](mailto:tech@penntexusa.com)